

Adjustable Expanding Shell Reamers Type H

Application:

The reamer for inline reaming of a series of holes, particularly the holes of bearing tunnels.

Design:

Right-hand cutting shell reamer with expanding blades.

The reamer fits on a tool bar and may be positioned along the tool bar at any desired position.

The reamer is automatically locked in place on the tool bar by an expanding spring coupling as soon as the reamer blades are brought into engagement with the bore.

Expanding tool bar guides and supporting fixtures for the tool bar are available to ensure exact alignment of the tool bar when reaming a series of aligned holes.

The adjusting nut is marked with a circular scale. One graduation of the scale corresponds to an alteration of the reamer diameter by 0,02 mm.



Size	Size Range mm	Takes Tool Bar d mm	Length Overall L1 mm	Length Blades L2 mm	Nut SW mm	No. of Blades	Weight kg
H 36	36 - 38	20	96	44	32	6	0,370
H 38	38 - 41	20	99	44	34	6	0,450
H 41	41 - 44	20	104	48	38	6	0,590
H 44	44 - 47	25	104	48	40	6	0,590
H 47	47 - 51	25	108	48	43	6	0,760
H 51	51 - 54	30	108	52	47	5	0,830
H 54	54 - 58	30	113	52	47	6	0,930
H 58	58 - 62	30	113	52	53	6	1,180
H 62	62 - 65	35	114	52	58	8	1,290
H 65	65 - 69	35	118	57	58	8	1,490
H 69	69 - 73	40	118	57	64	8	1,790
H 73	73 - 78	40	123	57	68	8	1,970
H 78	78 - 83	45	124	57	70	8	2,110
H 83	83 - 88	45	124	60	78	8	2,750
H 88	88 - 93	50	124	60	83	8	3,000
H 93	93 - 99	50	127	60	83	10	3,490
H 99	99 - 105	50	127	60	*	10	4,200
H 105	105 - 111	50	127	60	*	10	5,040

Reamers type H with size range over 111 mm on request.

* Adjustment of the nut with hook wrench.

Adjustable Expanding Shell Reamers Type H

Order Information:

The reamers are available with standard blades made from high quality special steel to ensure superior cutting efficiency.

The reamers are also available with hard chromium coated blades.

The hard chromium coating has superior hardness in combination with a low friction coefficient. Thus reamers of the „hard chromium“ series are particularly suitable for reaming abrasive materials and materials with a tendency to adhere to and to build-up the cutting edge.

Size	Reamers		Replacement Blades*		Front Nuts with Scale Part No.	Back Nuts Part No.	Replacement Springs Part No.
	Special Steel Part No.	Hard Chromium Part No.	Special Steel Part No.	Hard Chromium Part No..			
H 36	150 36 000	151 36 000	150 36 400	151 36 400	150 36 520	150 36 510	150 20 600
H 38	150 38 000	151 38 000	150 38 400	151 38 400	150 38 520	150 38 510	150 20 600
H 41	150 41 000	151 41 000	150 41 400	151 41 400	150 41 520	150 41 510	150 20 600
H 44	150 44 000	151 44 000	150 44 400	151 44 400	150 44 520	150 44 510	150 25 600
H 47	150 47 000	151 47 000	150 47 400	151 47 400	150 47 520	150 47 510	150 25 600
H 51	150 51 000	151 51 000	150 51 400	151 51 400	150 51 520	150 51 510	150 30 600
H 54	150 54 000	151 54 000	150 54 400	151 54 400	150 54 520	150 54 510	150 30 600
H 58	150 58 000	151 58 000	150 58 400	151 58 400	150 58 520	150 58 510	150 30 600
H 62	150 62 000	151 62 000	150 62 400	151 62 400	150 62 520	150 62 510	150 35 600
H 65	150 65 000	151 65 000	150 65 400	151 65 400	150 65 520	150 65 510	150 35 600
H 69	150 69 000	151 69 000	150 69 400	151 69 400	150 69 520	150 69 510	150 40 600
H 73	150 73 000	151 73 000	150 73 400	151 73 400	150 73 520	150 73 510	150 40 600
H 78	150 78 000	151 78 000	150 78 400	151 78 400	150 78 520	150 78 510	150 45 600
H 83	150 81 000	151 81 000	150 81 400	151 181 400	150 81 520	150 81 510	150 45 600
H 88	150 82 000	151 82 000	150 82 400	151 82 400	150 82 520	150 82 510	150 50 600
H 93	-	151 83 000	-	151 83 400	150 83 520	150 83 510	150 50 600
H 99	-	151 84 000	-	151 83 400	150 84 520	150 84 510	150 50 600
H 105	-	151 85 000	-	151 83 400	150 85 520	150 85 510	150 50 600

* Replacement blades are furnished in matched sets.
The blades are finish-ground and, therefore, no grinding is needed after the blades have been inserted in the reamer body.

Tool Bars for Reamers Type H

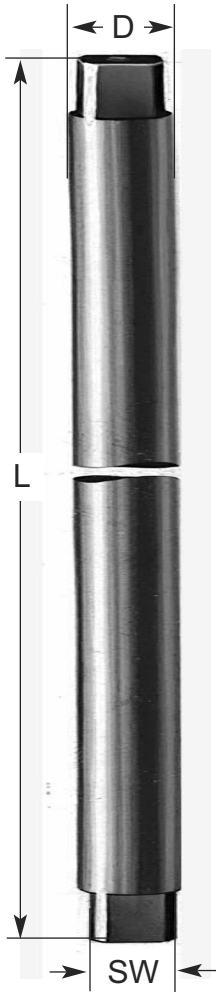

Application:

The tool bars are required to guide the shell reamer types H.

Design:

The tool bars are provided with squares at both ends so that a tap wrench may be applied at each end.

The tool bars are precision ground bars so that the reamers are precisely guided at each position along the bars.

Order Information:

Tool Bar		Diameter D mm	Length L mm	Square SW mm	Weight kg
Part No.	for Reamer Size				
152 20 101	H 36 - H 41	20	1000	13	2,420
152 25 101	H 44 - H 47	25	1000	13	3,740
152 30 121	H 51 - H 58	30	1200	16	6,540
152 30 151	H 51 - H 58	30	1500	16	12,000
152 35 121	H 62 - H 65	35	1200	18	8,750
152 40 151	H 69 - H 73	40	1500	18	14,400
152 45 151	H 78 - H 83	45	1500	22	18,110
152 50 171	H 88 - H 105	50	1700	22	25,200

Special length tool bars on request.

Expanding Tool Bar Guides

Application:

The tool bar guides are clamped into the holes of bearing tunnels to guide the tool bar.

Design:

The tool bar guides are provided with wedges which can be forced outward against the hole to lock the tool bar guide in the hole.

The wedges are actuated by an adjusting nut.



Order Information:

Tool Bar Guides		Bore d mm	Expansion Range mm	Weight kg
Part No.	for Reamer Size			
153 20 000	H 36 - H 41	20	35,5 - 54	0,200
153 25 000	H 44 - H 47	25	43,5 - 62	0,300
153 30 000	H 51 - H 58	30	49,5 - 74	0,410
153 35 000	H 62 - H 65	35	61,5 - 83	0,620
153 40 000	H 69 - H 73	40	68,5 - 93	0,800
153 45 000	H 78 - H 83	45	77,5 - 105	1,100
153 50 000	H 88 - H 105	50	87,5 - 127	1,550

Supporting Fixtures for Tool Bars

Application:

The universal supporting fixture is designed to locate a tool bar guide in front of an end bearing hole for perfect alignment of the tool bar in centerline with the hole.

Design:

The tool bar guide is locked in a clamping arm which is connected by a ball joint to a mounting base which is attached to the cylinder block or cylinder head.

Both the clamping arm and the ball joint are adjustable to ensure proper alignment.

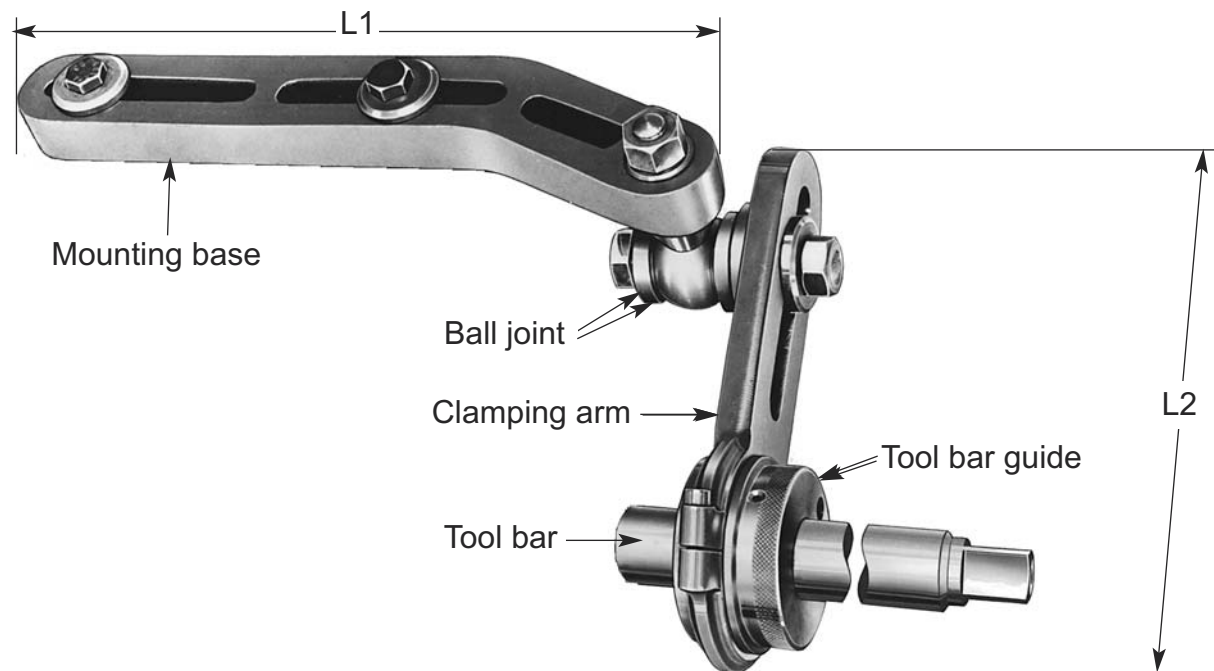

Order Information:

Size	Supportin Fixture		Individual Components of the Supporting Fixture						
	Part No.	Weight kg	Mounting Base			Clamping Arm			Ball Joint Part No.
			Size	Part No.	L1 mm	Size	Part No.	L2 mm	
IA	156 11 100	3,140	IA	156 11 110	330	IA	156 11 120	210	156 11 130
IIA	156 12 100	5,100	IIA	156 12 110	400	IIA	156 12 120	270	156 11 130
IIA1	156 12 102	5,100	IIA	156 12 110	400	IA	156 11 120	210	156 11 130

Expanding Tool Bar Guides for Clamping Arm Size IA			
Size	Part No.	Bore Dia. for Bar	Weight kg
IA/20	156 21 200	20 mm	0,920
IA/25	156 21 250	25 mm	0,880
IA/30	156 21 300	30 mm	0,820
IA/35	156 21 350	35 mm	0,750
IA/40	156 21 400	40 mm	0,650
IA/45	156 21 450	45 mm	0,600
IA/50	156 21 500	50 mm	0,550

Expanding Tool Bar Guides for Clamping Arm Size IIA			
Size	Part No.	Bore Dia. for Bar	Weight kg
IIA/40	156 22 400	40 mm	1,940
IIA/45	156 22 450	45 mm	1,890
IIA/50	156 22 500	50 mm	1,800

Accessories for Line Boring and Reaming

Boring Heads

Application:

The boring heads are designed for line boring the holes before finish reaming.

Design:

The boring heads are fitted with an adjustable single point cutting tool for boring the holes and for chamfering.

A set screw is provided to adjust the cutting tool.



Boring head Part No.	Dimensions		Weight kg
	Diameter of hole for tool bar d mm	Range of adjusting tool bar D mm	
154 30 000	30	50 - 58	0,340
154 31 000	30	53 - 62	0,420
154 35 000	35	61 - 69	0,520
154 40 000	40	68 - 78	0,660
154 45 000	45	77 - 88	0,870
154 50 000	50	87 - 99	1,230
154 52 000	50	92 - 105	1,440
154 54 000	50	98 - 111	1,670

Boring heads and tool bars for 20 & 25 mm on request.

Feed Devices

Application:

The feed device is locked just behind the expanding tool bar guide to move the of the tool bar in axial direction when the tool bar is rotated.

Design:

A knurled screw is provided for engaging and disengaging the automated axial feed.

The automated axial feed amount to 1mm per revolution of the tool bar.



Feed device Part No.	Diameter of hole for tool bar mm	Weight kg
155 20 000	20	0,330
155 25 000	25	0,360
155 30 000	30	0,730
155 35 000	35	0,760
155 40 000	40	0,830
155 45 000	45	0,840
155 50 000	50	0,850

Ludwig Hunger GmbH

Graefelfinger Str. 146
81375 Munich/Germany

Tel.: +49 89 7091-0
Fax: +49 89 7091-26

info@ludwig-hunger.de
www.ludwig-hunger.de